

nema

# MODELS AND ARTICLES

Expansion Vessels for HVAC, Water Supply  
and Sanitary Hot Water Applications

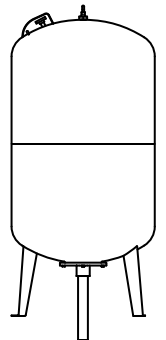
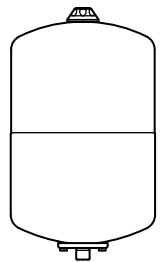
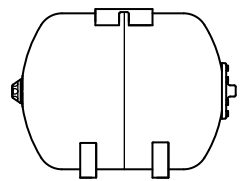

# WINKELMANN BUILDING + INDUSTRY: A STRONG ALLIANCE

Based in Ahlen in the German region of Westphalia and managed family-owned in the 4th generation, Winkelmann Building+Industry is one of the three main business units of the Winkelmann Group. The company designs and manufactures products and components of the highest quality with maximum production efficiency at a total of 7 sites in locations including Germany, Turkey, Poland and China.

Thanks to in-house research and development, collaboration with research institutions and government standardi-

sation bodies as well as the deployment of state-of-the-art production methods, the affiliated companies are among the most innovative in their sector. Our products and solutions for applications in heating, cooling, energy and plant engineering are worldwide known for their efficiency, performance and reliability.

Leading products, optimised processes and qualified employees provide the basis for satisfying our customers in the industry, in plant engineering, by wholesale trade as well as by installers.

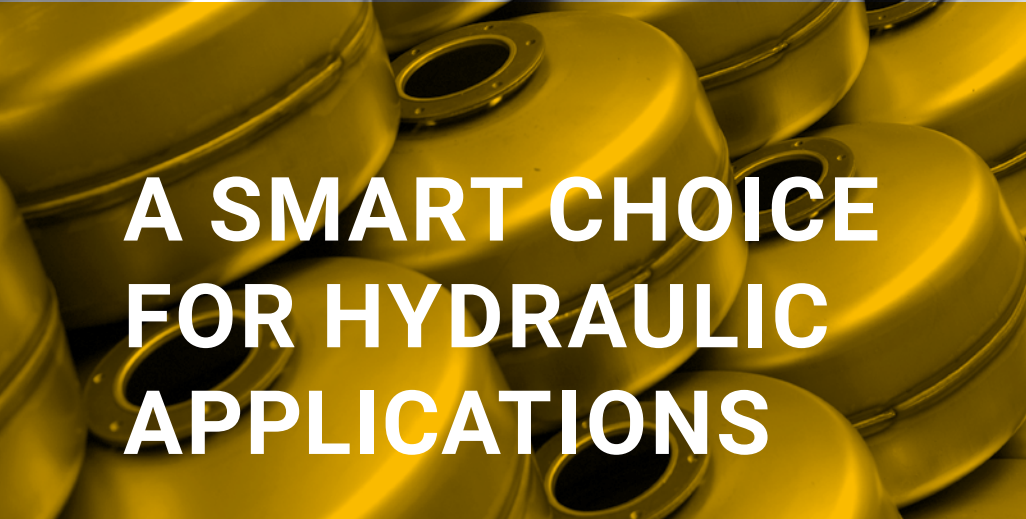

# A SMART CHOICE FOR HYDRAULIC APPLICATIONS



Durable and reliable: As a manufacturer of high-quality diaphragm pressure expansion vessels, Nema Winkelmann is able to draw on the expertise and optimised processes of the Winkelmann Group.

In its modern factory in the Turkish city of Düzce, the company produces a wide variety of high-performance pressure expansion vessels for heating and cooling systems, potable water and sanitary water systems as well as hot water storage systems.

Because Nema Winkelmann concentrates on what is really important, these products provide the perfect solutions to

numerous challenges in building technology applications involving the supply and delivery of water. Our vessels meet the most stringent requirements not only with regards to quality and reliability but also in terms of increasing cost sensitivity and time pressure during installation and assembly.

In accordance to ISO ISO 9001:2015 Quality Management System, all processes have been streamlined with most attention to quality, hence customer satisfaction. All our products are designed, manufactured and certified according to EN 13831 and PED 2014/68/EU respectively.

## FUNCTION PRINCIPLE OF EXPANSION VESSELS

The correct pressure is a prerequisite for the proper operation of heating, solar power and cooling water systems as well as pressure booster systems. It is essential to maintain water at a stable balance, compensate for variations in volume at regulated pressure and prevent gas separation and cavitation.

Expansion vessels offer an easy but intelligent solution. No external energy is needed, neither electrical power, a compressor or a pump. The construction of an expansion vessel is simple:

A bladder divides the vessel into a water and a gas chamber and therefore prevents gas from diffusing into the water.

While the water chamber is linked to the system by a vessel connection, the correct pressure in the gas chamber is set by using a filling valve at the top of the expansion vessel. The gas pressure is needed to balance changing water volume or pressure differences.

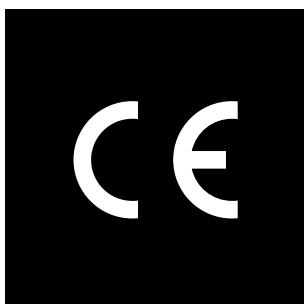
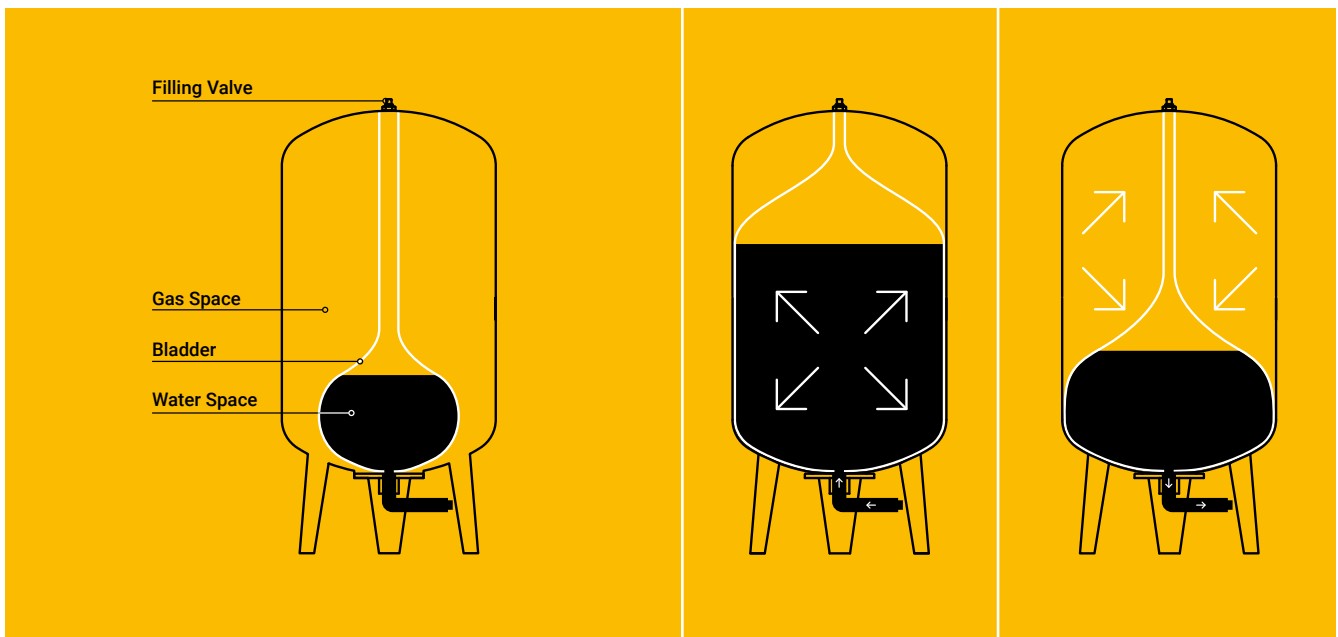

## CE MARKING AND DECLARATION OF CONFORMITY

CE marking is a part of the European Union's harmonisation legislation. It guarantees that products sold in the EEA have been assessed to meet high safety, health and environmental protection requirements.

Nema Winkelmann declares that all products meet the legal requirements for CE marking and can be sold throughout the EEA without restrictions.

## SCOPE OF APPLICATIONS

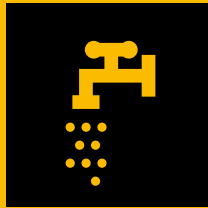

Water Supply Applications

In booster systems, vessels are used as buffer tanks to intermediately store the difference between the pumped volume flow and the volume flow actually needed. Vessels are also required to decrease the switching frequency of a pump and reduce peak loads.

The pressurised cushion of air in the gas space is set approximately below the pump's switch-on pressure. When pressure falls below the switch-on pressure, the pump switches on and pumps water. If consumers remove a relatively small volume of water, the difference in the buffer vessel is stored until the pressurised cushion of air on the switch-off side has compressed and the booster system has switched off. When consumers take water, the interim water is taken from the buffer vessel until the pressurised cushion of air has fallen to the switch-on pressure and the booster system switches on again.

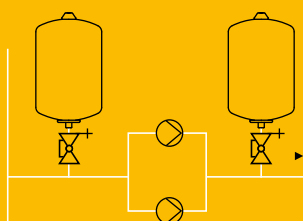

Sanitary Hot Water Applications

When heating sanitary water, pressure rises as the water expands. In the worst case, the excess pressure is decreased by a safety valve, losing valuable heated potable water. The use of a Nema expansion vessel remedies this situation by preventing the unnecessary opening of the safety valve and providing for a more efficient, resource-conserving operation of the system.

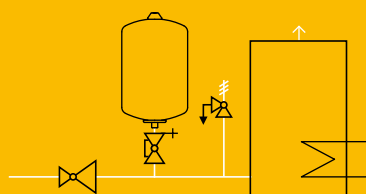



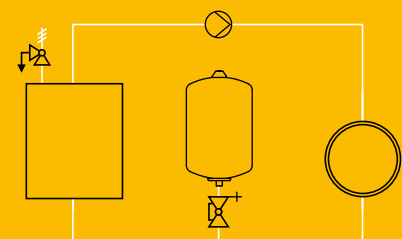

HVAC Applications

In closed heating-cooling systems, the water expands or contracts as the system is heated up or cooled down. Expansion vessels are used to compensate for the fluctuations in volume between maximum and minimum temperature within a permissible range.

Nema expansion vessels are used to maintain pressure in heating, cooling and solar power systems. The pressurised cushion of gas supports the water column within the system and is set before a reserve of water is poured into the vessel. When the system heats up, the pressure rises and expansion water flows from the external system into the water space: the pressurised cushion of air in the gas space is compressed. When the system cools down and its pressure drops, this counter pressure pushes water from the membrane back into the system. This releases the pressurised cushion of air in the gas space.

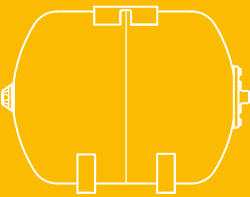

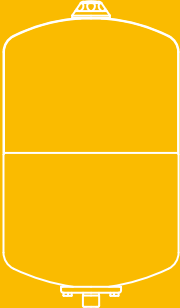
MODEL RANGE

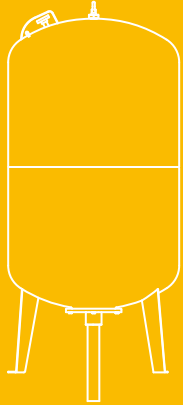
<p><b>MODEL</b> <b>NEQ</b></p>  <p>Water Supply Applications    Sanitary Hot Water Applications</p> 	<p><b>MODEL</b> <b>NEL</b></p>  <p>Water Supply Applications    Sanitary Hot Water Applications    HVAC Applications</p> 	<p><b>MODEL</b> <b>NEX</b></p>  <p>Water Supply Applications    Sanitary Hot Water Applications    HVAC Applications</p> 
<p>24 – 100 lt</p>	<p>5 – 60 lt</p>	<p>50 – 5,000 lt</p>
<p>BAR <b>10</b></p>	<p>BAR <b>6</b> — <b>25</b></p>	<p>BAR <b>6</b> — <b>25</b></p>

## CHOOSE YOUR PRODUCT

We have three ranges available for your requirement/project: NEQ, NEL and NEX. Our products can be customised based on volume, type of installation, pressure requirement, the correct diaphragm and the colour of the vessel. Please use the structure outlined below to put together the order number for your selected product.

8.	00008	.01	06	1 0	1 0
	Volume	Type	PN rating	Bladder	Colour
<b>8.</b>	<b>00008</b>	<b>.01</b>	<b>06</b>	<b>1 0</b>	<b>1 0</b>
	5–5,000 lt	01 Vertical 02 Horizontal (NEQ) 03 Vertical without feet (NEL) 04 Sphere (NEL) 07 Vertical with hanger	06 10 16 25	1 0 EPDM, Air 1 1 Butyl, Air 1 2 EPDM, Nitrogen 1 3 Butyl, Nitrogen	1 0 Red 3 0 Blue

## ORDER PROCESS



We look forward to hearing from you and would be delighted to provide additional information or answer any questions you might have in relation to your purchase order:

+90 (380) 745 11 29

info@nema-winkelmann.com.tr

NEMA WINKELMANN Isıtma ve Su Teknolojileri San. ve Tic. Ltd. Şti.  
Yakabaşı Mah. | Kocaalan Mevkii | 81850 Gümüşova/Düzce | TURKEY

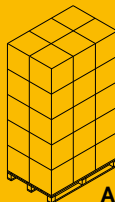
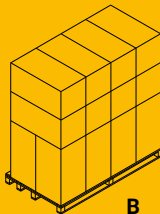
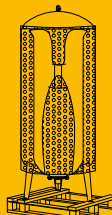
## PACKAGING TYPES

A	carton box	80 x 120 cm pallet		
B	carton box	100x220 cm pallet		
C1	carton box	68 x 101 cm pallet		
C2		68 x 127 cm pallet		
C3		74 x 156 cm pallet		
D1	bubble wrap	86 x 86 cm pallet		
D2		95 x 95 cm pallet		
D3		110 x 110 cm pallet		
E	bubble wrap	horizontal on pallet		
F1	bulk method	5 lt – 150 lt		
F2		200 lt – 500 lt		
F3		600 lt – 5,000 lt		

MODEL  
**NEQ**



TYPE  
Horizontal

BLADDER COLOUR

EPDM Air	Red
<b>10</b>	<b>10</b>
Butyl Air	Blue
<b>11</b>	<b>30</b>
EPDM N <sub>2</sub>	
<b>12</b>	
Butyl N <sub>2</sub>	
<b>13</b>	

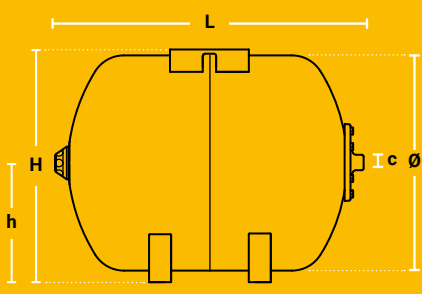

- In accordance to 2014/68/EU Pressure Equipment Directive and TS-EN 13831 standards
- Interchangeable bladder according to DIN 4807-3 norms, EPDM standard, Butyl optional
- Electrostatic Powder Coating
- Maximum working temperature for bladder: -10 °C / +70 °C
- Instantaneous maximum operating temperature: +110 °C (the expansion vessel must be connected to the return line)
- Suitable for Water and Water-Glycol mixtures (max. 50% glycol, Fluid group 2 according to 2014/68/EU Directives)

PN	Art. No.	V (lt)	Dia Ø (mm)	H (mm)	L (mm)	h (mm)	C (G ISO 228-1)	Weight (kg)	Pre-charge (bar)	Std. Pack (pcs.)	
10 BAR	8.00024.0210 <b>10</b> <b>30</b>	24	280	328	484	180	1**	5.5	2	30 (A)	90 (B)
	8.00050.0210	50	410	454	518	238	1**	9.2		16 (A)	40 (B)
	8.00060.0210	60	410	454	588	238		9.5	16 (A)	40 (B)**	
	8.00080.0210	80	480	518	621	267		13.4	4	8 (A)	16 (B)
	8.00100.0210	100	480	518	699	267	14.7	8 (A)		16 (B)	

\* (Optional 3/4")  
\*\* Pallet size: 120x220 cm



<b>MODEL</b>  <b>NEL</b>			
	TYPE Vertical	TYPE Vertical without Feet	TYPE Sphere

**BLADDER COLOUR**

EPDM Air	Red
<b>10</b>	<b>10</b>
Butyl Air	Blue
<b>11</b>	<b>30</b>
EPDM N <sub>2</sub>	
<b>12</b>	
Butyl N <sub>2</sub>	
<b>13</b>	

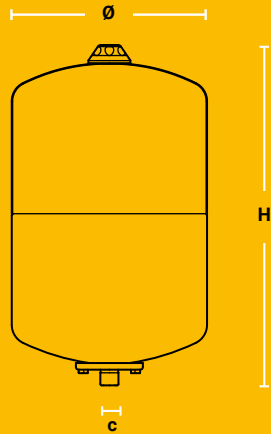

- In accordance to 2014/68/EU Pressure Equipment Directive and TS-EN 13831 standards
- Interchangeable bladder according to DIN 4807-3 norms, EPDM standard, Butyl optional
- Electrostatic Powder Coating
- Maximum working temperature for bladder: -10 °C / +70 °C
- Instantaneous maximum operating temperature: +110 °C (the expansion vessel must be connected to the return line)
- Suitable for Water and Water-Glycol mixtures (max. 50% glycol, Fluid group 2 according to 2014/68/EU Directives)

PN	Art. No.	V (lt)	Dia Ø (mm)	H (mm)	h (mm)	C (G ISO 228-1)	Weight (kg)	Precharge (bar)	Std. Pack (pcs.)	
6 BAR	8.00005.0106	5	220	233	-	1"	1.7	2	120 (A)	N/A
	8.00008.0106	8	220	296	-		2.3		80 (A)	N/A
	8.00012.0106	12	220	410	-		2.8		80 (A)	N/A
	8.00019.0106	19	280	434	-		3.8		36 (A)	90 (B)
	8.00024.0106	24	280	484	-	1"	4.0		36 (A)	90 (B)
	8.00035.0306	35	354	465	-		5.5		22 (A)	72 (B)
	8.00050.0306	50	410	523	-		7.4		15 (A)	40 (B)
	8.00060.0306	60	410	593	-		7.6		15 (A)	40 (B)**
10 BAR	8.00005.0110	5	220	233	-	1"	1.7	2	120 (A)	N/A
	8.00008.0110	8	220	296	-		2.3		80 (A)	N/A
	8.00012.0110	12	220	410	-		2.8		80 (A)	N/A
	8.00019.0110	19	280	434	-		3.8		36 (A)	90 (B)
	8.00024.0110	24	280	484	-	1"	4.0		36 (A)	90 (B)
	8.00035.0310	35	354	465	-		5.5		22 (A)	72 (B)
	8.00050.0310	50	410	523	-		7.4		15 (A)	40 (B)
	8.00060.0310	60	410	593	-		7.6		15 (A)	40 (B)**
	8.00024.0410	24 Sphere	354	353	-	1"	4.4		2	30 (A)
16 BAR	8.00019.0116	19	280	434	-	1"	6.3	2	36 (A)	90 (B)
	8.00024.0116	24	280	494	-		6.8		36 (A)	90 (B)
25 BAR	8.00019.0125	19	280	443	-	1"	8.7	2	36 (A)	90 (B)
	8.00024.0125	24	280	496	-		9.5		36 (A)	90 (B)

\* (Optional ¾")

\*\* Pallet size: 120x220 cm

MODEL  
**NEX**



TYPE  
Vertical

BLADDER COLOUR

EPDM Air

Red

**10**

**10**

Butyl Air

Blue

**11**

**30**

EPDM N<sub>2</sub>

**12**

Butyl N<sub>2</sub>

**13**

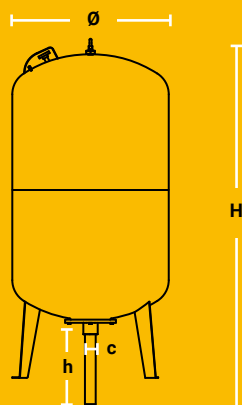

- In accordance to 2014/68/EU Pressure Equipment Directive and TS-EN 13831 standards
- Interchangeable bladder according to DIN 4807-3 norms, EPDM standard, Butyl optional
- Electrostatic Powder Coating
- Maximum working temperature for bladder: -10 °C / +70 °C
- Instantaneous maximum operating temperature: +110 °C (the expansion vessel must be connected to the return line)
- Suitable for Water and Water-Glycol mixtures (max. 50% glycol, Fluid group 2 according to 2014/68/EU Directives)
- Manometer (100 liters and above)

PN	Art. No	V (lt)	Dia Ø (mm)	H (mm)	h (mm)	C (G ISO 228-1)	Weight (kg)	Precharge (bar)	Std. Pack (pcs.)	
6 BAR	8.00050.0106	50	410	650	130	1"	8.2	2	15 (A)	40 (B)
	8.00060.0106	60	410	721	130		8.6		15 (A)	40 (B)*
	8.00080.0106	80	480	791	170	1"	12.4	4	8 (A)	16 (B)
	8.00100.0106	100	480	924	170		14.4		8 (A)	16 (B)
	8.00140.0106	140	480	1,135	175	1 ¼"	20.6	4	16 (B)	
	8.00200.0106	200	634	1,008	185		31.4		3 (C1)	
	8.00250.0106	250	634	1,123	185	1 ¼"	35.2	4	3 (C2)	
	8.00300.0106	300	634	1,296	185		40.6		3 (C2)	
	8.00400.0106	400	740	1,428	240	2"	56.4	4	3 (C3)	
	8.00500.0106	500	740	1,586	240		62.0		3 (C3)	
	8.00600.0106	600	848	1,585	185	2"	101.0	4	1 (D1)	
	8.00750.0106	750	848	1,786	185		116.6		1 (D1)	
	8.00800.0106	800	848	1,881	185		124.0		1 (D1)	
	8.01000.0106	1,000	848	2,186	185		143.2		1 (D1)	
10 BAR	8.00050.0110	50	410	650	130	1"	8.2	2	15 (A)	40 (B)
	8.00060.0110	60	410	721	130		8.6		15 (A)	40 (B)*
	8.00080.0110	80	480	791	170	1"	12.4	4	8 (A)	16 (B)
	8.00100.0110	100	480	924	170		14.4		8 (A)	16 (B)
	8.00140.0110	140	480	1,135	170	1 ¼"	20.6	4	16 (B)	
	8.00200.0110	200	634	1,008	185		31.4		3 (C1)	
	8.00250.0110	250	634	1,123	185	1 ¼"	35.2	4	3 (C2)	
	8.00300.0110	300	634	1,296	185		40.6		3 (C2)	
	8.00400.0110	400	740	1,428	240	2"	56.4	4	3 (C3)	
	8.00500.0110	500	740	1,586	240		62.0		3 (C3)	
	8.00600.0110	600	848	1,585	205	2"	101.0	4	1 (D1)	
	8.00750.0110	750	848	1,786	205		116.6		1 (D1)	
	8.00800.0110	800	848	1,881	205		124.0		1 (D1)	
	8.00850.0110	850	848	1,990	205		140.0		1 (D1)	
	8.01000.0110	1,000	848	2,187	205	2"	143.2	4	1 (D1)	
	8.01500.0110	1,500	958	2,480	190		270.0		1 (D2)	
	8.02000.0110	2,000	1,200	2,375	270		373.0		1 (D3)	

\* Pallet size: 120x220 cm

PN	Art. No.	V (lt)	Dia Ø (mm)	H (mm)	h (mm)	C (G ISO 228-1)	Weight (kg)	Precharge (bar)	Std. Pack (pcs.)	
10 BAR	8.02500.0110	2,500	1,200	2,750	230	2 ½"	450.0	4	1 (E)	
	8.03000.0110	3,000	1,500	2,355	240		609.0		1 (E)	
	8.04000.0110	4,000	1,500	2,900	240		729.0		1 (E)	
	8.05000.0110	5,000	1,500	3,475	235	3"	915.0		1 (E)	
16 BAR	8.00050.0116	50	410	650	120	1"	12.8	4	15 (A)	40 (B)
	8.00080.0116	80	480	810	160		20.0		8 (A)	16 (B)
	8.00100.0116	100	480	915	160		20.6		8 (A)	16 (B)
	8.00140.0116	140	480	1,135	165		31.5		16 (B)	
	8.00200.0116	200	634	1,010	145	1 ¼"	48.8		3 (C1)	
	8.00300.0116	300	634	1,298	145		65.2		3 (C2)	
	8.00500.0116	500	800	1,480	185	2"	156.6		3 (C3)	
	8.00750.0116	750	800	1,981	180		203.0		1 (D1)	
	8.01000.0116	1,000	850	2,355	180	2 ½"	261.0		1 (D1)	
	8.01500.0116	1,500	1,200	1,970	235		444.0		1 (D2)	
	8.02000.0116	2,000	1,200	2,390	235	3"	550.0		1 (D3)	
	8.02500.0116	2,500	1,200	2,810	225		720.0		1 (E)	
	8.03000.0116	3,000	1,500	2,378	235	2 ½"	765.0		1 (E)	
	8.04000.0116	4,000	1,500	2,922	235		955.0		1 (E)	
8.05000.0116	5,000	1,500	3,525	230	3"	1,154.4	1 (E)			
25 BAR	8.00050.0125	50	500	665	110	1"	40.0	5	15 (A)	40 (B)
	8.00100.0125	100	500	888	188		55.6		8 (A)	16 (B)
	8.00140.0125	140	500	1,140	175		80.0		16 (B)	
	8.00200.0125	200	600	1,153	130	1 ¼"	138.6		3 (C1)	
	8.00300.0125	300	640	1,415	190		137.8		3 (C2)	
	8.00500.0125	500	800	1,480	185	2"	203.6		3 (C3)	
	8.00750.0125	750	800	1,935	165		260.0		1 (D1)	
	8.01000.0125	1,000	850	2,355	170	2 ½"	286.0		1 (D1)	
	8.01500.0125	1,500	1,200	1,970	205		619.3		1 (D2)	
	8.02000.0125	2,000	1,200	2,370	205	3"	720.0		1 (D3)	
	8.02500.0125	2,500	1,200	2,888	205		870.6		1 (E)	
	8.03000.0125	3,000	1,500	2,482	230	2 ½"	1,140.0		1 (E)	
	8.04000.0125	4,000	1,500	2,977	230		1,423.4		1 (E)	
	8.05000.0125	5,000	1,500	3,550	220	3"	1,665.0		1 (E)	

nema – your smart choice  
for hydraulic applications.

[www.nema-winkelmann.com](http://www.nema-winkelmann.com)

NEeng / 1222

**NEMA WINKELMANN**

Isıtma ve Su Teknolojileri San. ve Tic. Ltd. Şti.

Yakabaşı Mah.  
Kocaelan Mevkii,  
81850 Gümüşova/Düzce  
TURKEY

A WINKELMANN  
BUILDING+INDUSTRY BRAND